

**DFSL-32, 36**

**ARTICULATED INSULATED  
AERIAL LIFTS**

**BRAND**



DFSL Lifts with working heights to 38' and side reaches to 20' provide many features usually seen only on larger machines. A wide range of power systems and controls make this the machine for all applications. Fully insulated upper booms have a 46 KV rating.



# DFSL-32, 36

## SPECIFICATIONS

	Model DFSL-32	Model DFSL-36
Height to Bottom of Platform	29'	33'
Working Height	34'	38'
Side Reach	17' 10"	19' 10"
Stowed Travel Height	10'	10'
Basket Capacity	300 lb.	300 lb.
Approx. Installed Weight	1800 lb.	1850 lb.
Lower Boom Travel	0 to 92°	0 to 92°
Upper Boom Travel	0 to 133°	0 to 133°
Upper Boom Fiberglass Length	9' 4"	11' 6"
Minimum GVWR	11,000 GVWR	11,000 GVWR



## REACH & ELEVATION

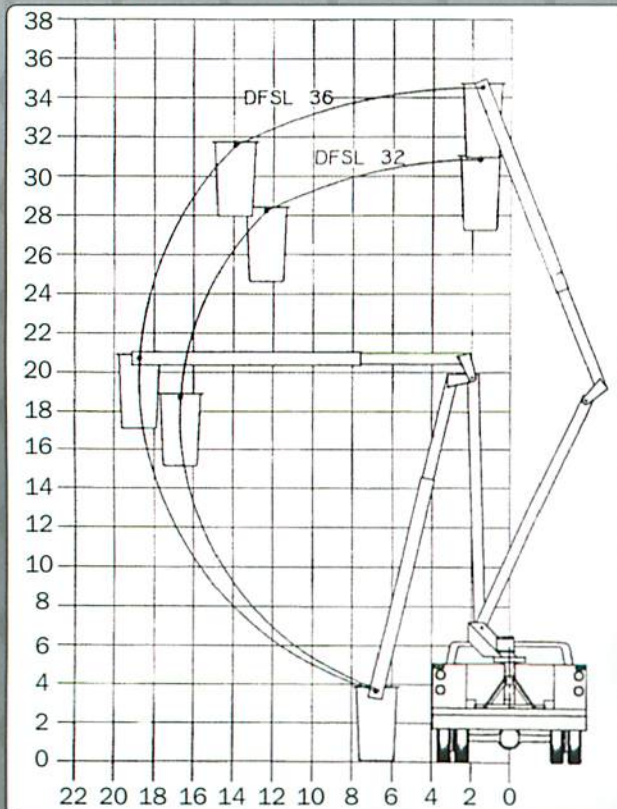

## CONTROLS

- Upper Control Override at the Turntable.
- Three Control Levers at the Turntable and Basket, with Deadman at the Basket.
- Engine Start/Stop from the Basket.

## HYDRAULIC SYSTEM

- Open Center System.
- Rated pressure is 2000 PSI.
- Operating pressure is 1800 PSI.

## MECHANICAL SYSTEM

- Glass rods and chain by parallelogram basket levelling system with easy service access.
- Rotation by hydraulic driven worm gear.
- 370° Rotation.

## SAFETY FEATURES

- Holding valves in all cylinders.
- Pressure relief valve.
- Non-conductive hoses and fiberglass rods provide levelling and control through the insulated boom section.
- 46 KV Category "C" Insulation.
- Upper Boom Tie Down.
- Safety Belt and Lanyard.

## OPTIONAL FEATURES

- Continuous Rotation.
- Outriggers
- 12 volt D.C. Backup.
- Single Hand Controls.\*  
\*(Full Pressure Controls Only)
- Basket Liner.
- Basket and Control Cover.
- Basket Tilt System.
- Automatic or Two-Speed Throttle Advance.
- Fan Belt or PTO Power.
- Non-insulated Machines Available.

# DUR-A-LIFT

P.O. Box 31 • 2002 Kingbird Ave.  
George, IA 51237  
Ph: 877-4-DURALIFT (877) 438-7254  
Fax: 712-475-2809  
sales@dur-a-lift.com  
www.dur-a-lift.com